

Accessible Medical Facilities and Equipment

**Kaylan M. Dunlap, CAsp, ADAC, LPTA
Evan Terry Associates, LLC**

Learning Objectives

- Review accessibility requirements specific to healthcare facilities
- Discuss typical barriers to accessibility in healthcare facilities
- Demonstrate readily achievable barrier removal in the healthcare setting
- Identify maintenance of accessible features, policies and procedures that should be considered in a healthcare setting
- List accessible diagnostic medical equipment requirements

- ADA
 - Federal civil rights law that prohibits discrimination against individuals with disabilities in every day activities
 - Includes medical services and health care
- Section 504 of the Rehabilitation Act of 1973 Section 504
 - Civil rights law that prohibits discrimination against individuals with disabilities on the basis of their disability in programs or activities that receive federal financial assistance
 - Includes health programs and services
 - Covers facilities that receive federal financial assistance





- State and Local Government Services (Title II)
 - State and local government facilities
 - Public hospitals and clinics and medical offices operated by state and local governments
- Public Accommodations (Title III)
 - Places of Public Accommodation
 - Commercial Facilities
 - Private hospitals and medical offices

- New construction
- Alterations
- Existing facilities
 - Title II – Program Access
 - Program as a whole must be accessible
 - Removing architectural barriers or
 - Adopting alternative measures, such as relocating activities to accessible locations
 - Title III – Readily Achievable Barrier Removal
 - Readily achievable - when it is easily accomplishable and able to be carried out without much difficulty or expense
 - If barrier removal is not readily achievable, entity must make services available through alternative methods, if those methods are readily achievable



MEDICAL CARE AND LONG-TERM CARE FACILITIES

DOJ Guidance Document

- Technical assistance document published by the Department of Justice in regard to providing accessible healthcare for people with mobility disabilities

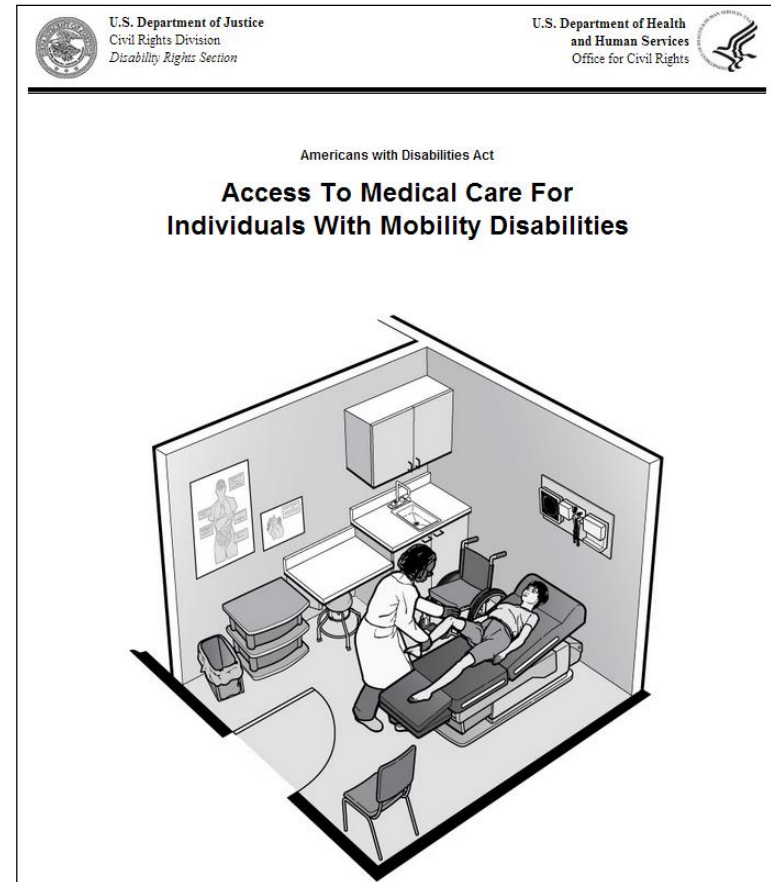

Medical Care and Long-Term Care Facilities (223.1)



- Licensed medical care facilities and licensed long-term care facilities where period of stay exceeds 24 hours
- Applies to patient or resident sleeping rooms
- Exception: toilet rooms that are part of critical care or intensive care patient rooms

Medical Care and Long-Term Care Facilities (223.1)

- The dispersion requirement is found in the ADA Regulations
 - **35.151(h) (Title II)**
 - **36.406(g) (Title III)**
- Isolation rooms should be included in dispersion

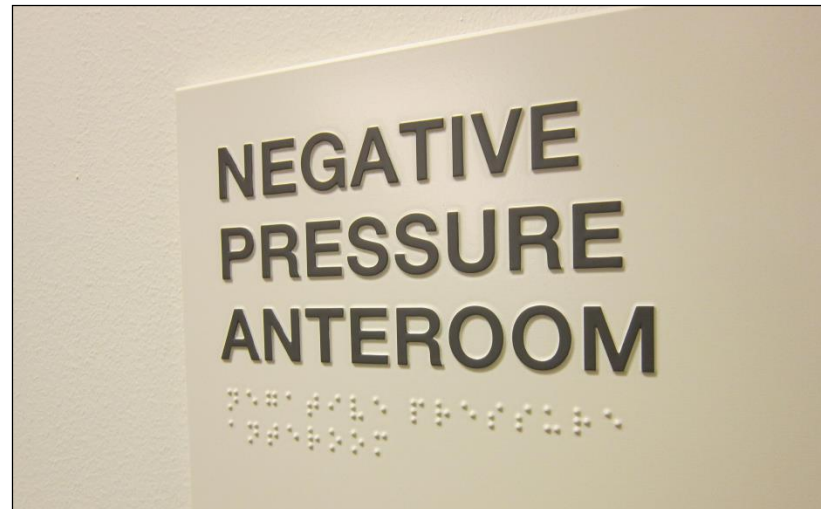

Medical Care and Long-Term Care Facilities (223.1.1)



- Alterations
- Based on the number of patient rooms being altered or added, not the total number of patient rooms

Hospitals, Rehabilitation Facilities, Psychiatric Facilities, and Detoxification Facilities (223.2)

- 10% minimum, but no fewer than one, of patient sleeping rooms required to provide mobility features in facilities not specializing in treating conditions that affect mobility
- 100% of patient sleeping rooms required to provide mobility features in facilities specializing in treating conditions that affect mobility
- At least 50% of resident sleeping rooms required to provide mobility features in licensed long-term care facilities



Medical Care and Long-Term Care Facilities (805)



- Turning space required within the room
- Clear floor space on each side of the bed for parallel approach to the side of the bed
- Toilet and bathing rooms as part of sleeping room must be accessible

Patient Room Door Maneuvering Clearance (404.2.4)

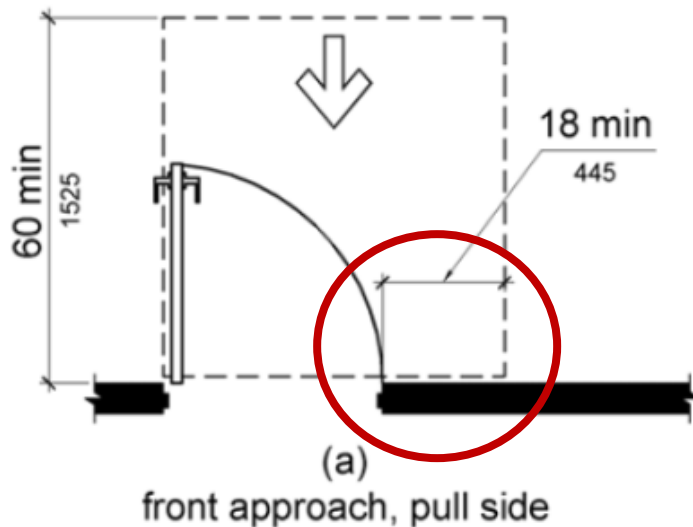

- Exception for latch side door maneuvering clearance

404.2.4 Maneuvering Clearances...

EXCEPTION: Entry doors to hospital patient rooms shall not be required to provide the clearance beyond the latch side of the door.

Telephones (217.4.6)



- Where at least 1 public pay telephone is provided serving a HOSPITAL emergency, recovery, or waiting room: 1 minimum TTY required at each location

Exercise Equipment (236.1)

- 2010 Standards require at least one of each type of exercise machine and equipment to be on an accessible route

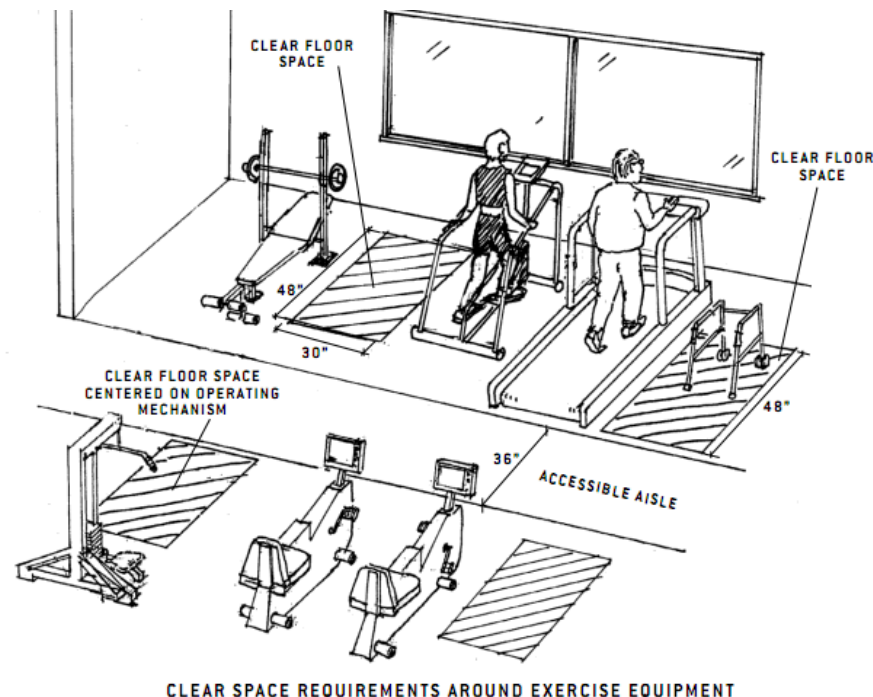

Image from "Accessible Sports Facilities – A Summary of Accessibility Guidelines for Recreation Facilities"

Exercise Equipment (1004.1)



- 30" x 48" clear floor space for a person in a wheelchair to make a transfer
- Clear floor spaces at adjacent machines may overlap

Patient Lifts

- Ceiling lifts
 - Serve only one room
 - No storage space necessary

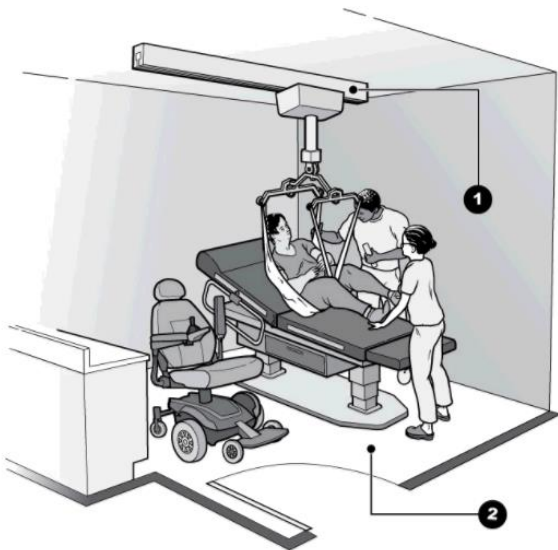

- Portable lifts
 - Space needed for storage
 - Space needed for maneuvering



Images from "Access To Medical Care For Individuals With Mobility Disabilities"

Portable Patient Lifts

- Storage
- Training for staff
- How many lifts are appropriate for the clinic, doctor's office, or nursing unit?
- Lift slings
- Will require clear floor space or clearance under the medical equipment so that the U-shaped lift base can get close enough to allow the sling to be over the table surface



Diagnostic Medical Equipment

- Ceiling lifts
 - Clear floor space or clearance under the equipment isn't necessary as with a portable lift
 - Extra maneuvering space within the room isn't necessary as with a portable lift
 - One ceiling lift serves one room



Accessible Route to Exam Room

- Route kept clear of stored items
 - Spaces designed specifically for storage of items such as soiled linen carts, crash carts, computer stations can be helpful
 - Policy for storage of items in corridors, particularly egress corridors

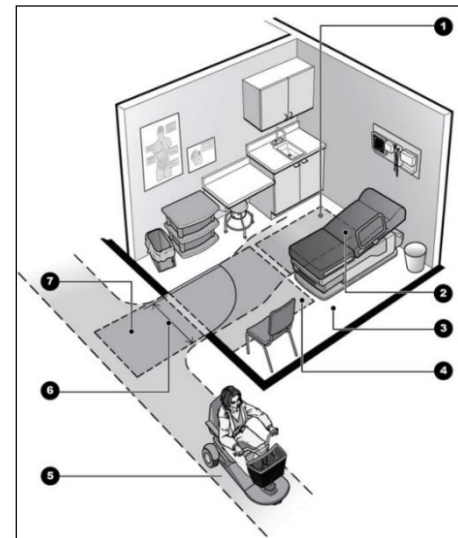

Image from "Access To Medical Care For Individuals With Mobility Disabilities"

Accessible Entrance into Exam Room

- Door maneuvering clearance kept clear of stored items (boxes, equipment, chairs)

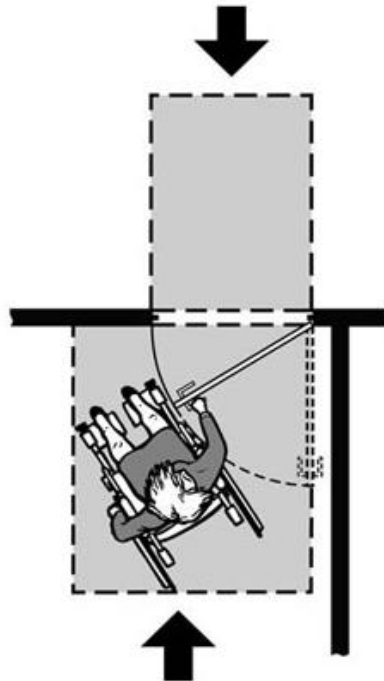
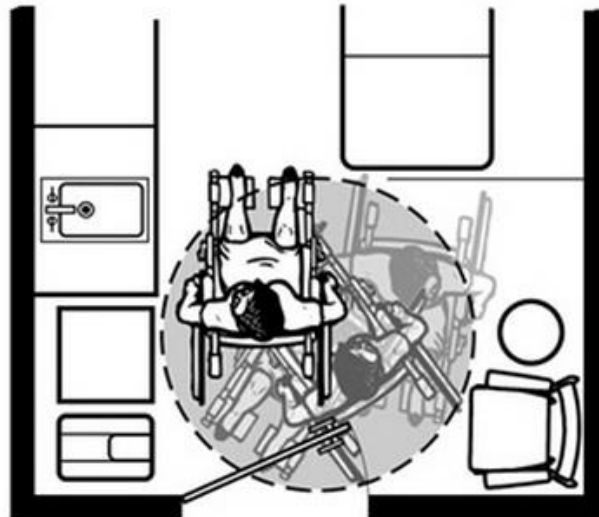

Image from "Access To Medical Care For Individuals With Mobility Disabilities"

Accessible Route Through Exam Room

- Turning space in the exam room is not required by the ADA Standards, but is recommended in the [DOJ guidance document](#)
 - Policy in existing facilities to relocate items by moving chairs, stools, trash cans as needed to provide space per DOJ medical care document



Electronic Medical Record Stations



- Electronic Medical Record stations
 - Protruding objects
 - Maneuvering clearance
- Portable units (WOWs or COWs)
 - Storage space
 - Charging needs

Sharps Boxes



- Sharps boxes
 - Reach range and clear floor space as a reasonable accommodation for employees with disabilities
 - Protruding objects for public, patients, visitors

Exam Rooms

- Many exam room designs show the exam table with the head at a corner
 - Limits clear floor space for transfer
 - Limits space for healthcare personnel performing exams or treatments



Image from "Access To Medical Care For Individuals With Mobility Disabilities"

Exam Rooms

- Clear floor space at exam table/chair
 - Clear floor space on at least one side (parking space for wheelchair or scooter so a transfer can be made)
 - Space for lift equipment to be used

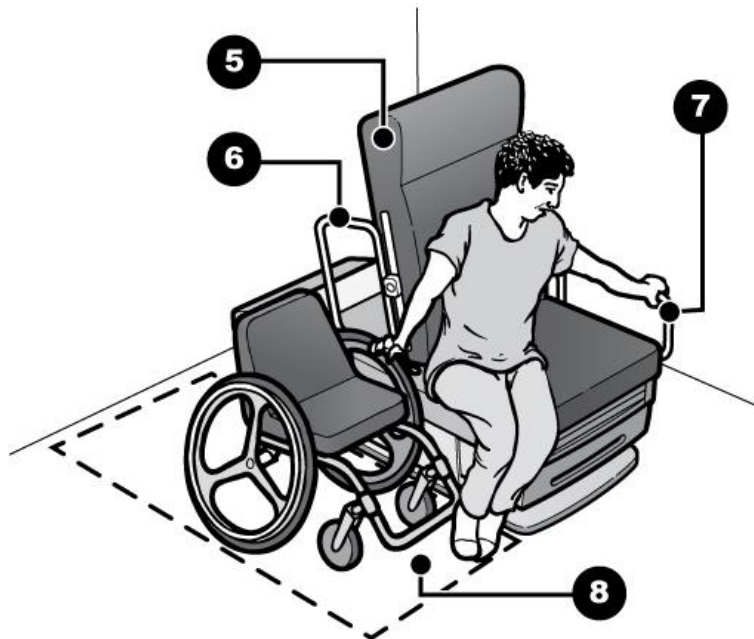

Image from "Access To Medical Care For Individuals With Mobility Disabilities"



Equipment



- Exam, diagnostic, and treatment equipment placement
- Coordination
- Scheduling
- Storage space

Sinks



- Exam room and patient room sinks
- Medical staff only to avoid cross-contamination or safe hygiene for everyone?

Sinks



- Public use, patient use, and employee use
 - Corridors
 - Conference rooms
 - Waiting rooms, etc.
- Public/visitor use for handwashing?
- Many facilities have a policy that all visitors must wash hands before entering and upon leaving the patient room

Sinks



- Scrub sink
 - Reasonable accommodation for employees
 - Would anyone other than employees ever use this sink?
 - Foot or knee control operation

Toilet Rooms



- Split grab bars
- Exception 2 in 604.5.2 does not apply to bedpan flush mechanisms

Toilet Rooms



- Specimen pass-through cabinet
 - Clear floor space
 - Grab bar clearance
 - Reach range
 - Operation



Toilet Rooms



- Call buttons
 - Reach range
 - Grab bar clearances
 - Where is the button likely to be used?
 - Does a pull cord change that in any way?



Operable Parts

- Window blinds/shades (conference rooms, patient rooms, waiting rooms)
 - New construction vs. barrier removal
 - Reach range
 - Operation

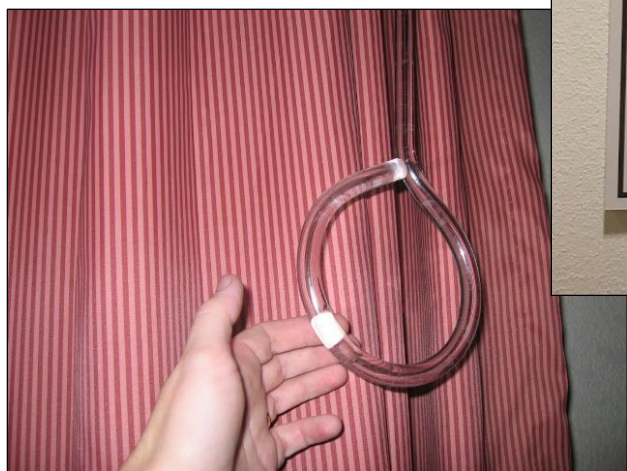

Waiting Rooms



- “Parking space(s)” for wheelchairs and scooters

Audiology Booths

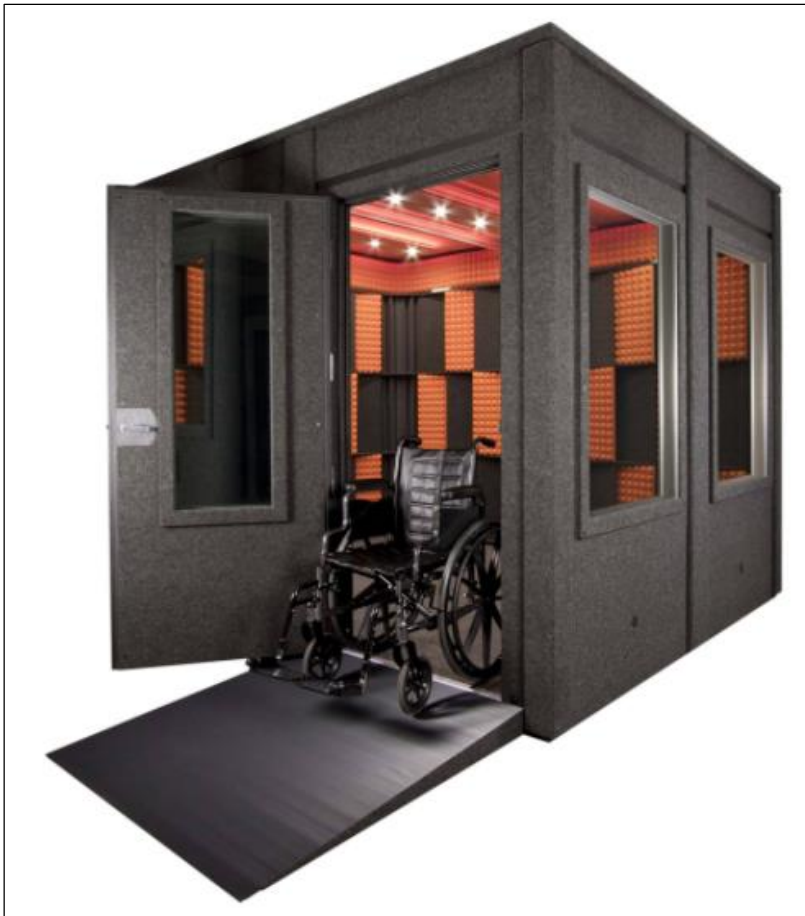

- Ceiling and door height
- Door to booth
 - Maneuvering clearance
 - Opening force
 - Threshold/step
- Size of booth

Eye Care



- Access to exam chair
 - “Chair glide” used to allow exam chair to be moved back
 - Raises seat height of exam chair and is a larger footprint than just the exam chair
 - How does this work with mirrors used in exam?
 - Knee clearance

Counters



- At least one of each type of sales and service counters
- More than one physician in an office, each with a different sign-in or check-out window...what to do?

Hand Sanitizers



- Placement below raised letter and braille signage may limit readability of sign
- Have been called out as protruding objects in DOJ settlement agreements
- Reach range
- Clear floor space
- Operation

Refreshment Stations



- Ice/drink machine
- Sink
- Refrigerator

Most Common Barriers in Healthcare Facilities

- Trash cans and other objects in door maneuvering clearances, required turning spaces, and clear floor spaces at fixtures, dispensers, and other accessible elements
- Toilet dispenser mounting location
- Dispensers and controls (coat hooks, soap and paper towel dispensers, hand sanitizers) - reach range, clear floor space, operation
- Door closer forces and closing speeds

Most Common Barriers in Healthcare Facilities

- Pipe insulation at lavatories
- Protruding objects
- Raised letter and braille signage (either not provided or mounting height)
- Objects stored on the accessible sections of counters
- Toilet room mirror height

Movable Objects in Door Maneuvering Clearance



Toilet room – room where people enter and exit unsupervised



Exam room – patients are escorted to the room but are left on their own

Waiting room – patients are escorted from waiting area to procedure area



Obstructions in Water Closet Clear Floor Space



- How large/heavy is the obstruction?
- Is it something that could or would be nudged away?



Toilet Paper Dispenser Mounting Location



Dispenser Mounting Height in Toilet Rooms



Door Closer (Speed and Force)



Pipe Insulation/Protection at Lavatories



- Safety consideration with the potential for skin coming into contact with hot pipes or a sharp element that could break one's skin

Protruding Objects



Raised Letter and Braille Signage



Objects Stored on Accessible Counters

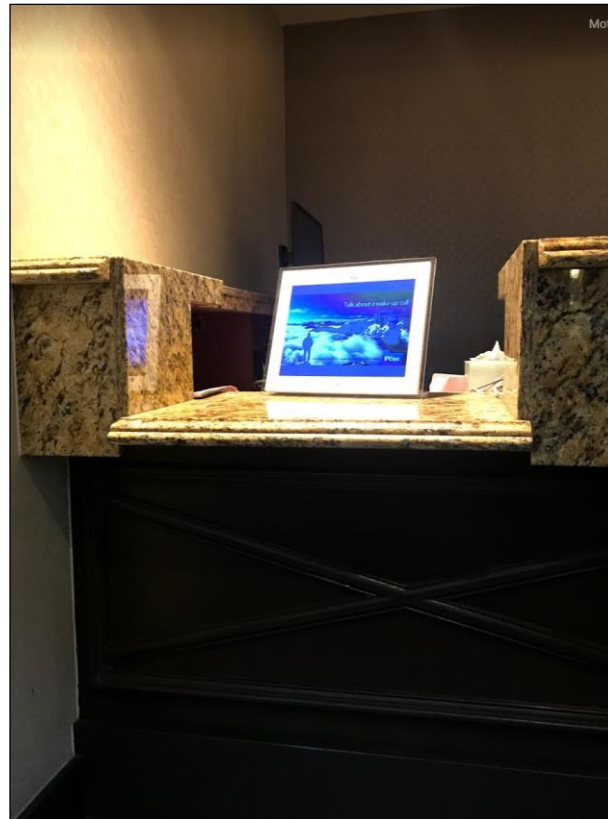

Toilet Room Mirror Height



READILY ACHIEVABLE BARRIER REMOVAL IN THE HEALTHCARE SETTING

Readily Achievable Barrier Removal (Title III)

Readily achievable means **easily accomplishable and able to be carried out without much difficulty or expense**. In determining whether an action is readily achievable factors to be considered include – (1) The nature and cost of the action needed under this part; (2) The overall financial resources of the site or sites involved in the action; the number of persons employed at the site; the effect on expenses and resources; legitimate safety requirements that are necessary for safe operation, including crime prevention measures; or the impact otherwise of the action upon the operation of the site; (3) The geographic separateness, and the administrative or fiscal relationship of the site or sites in question to any parent corporation or entity; (4) If applicable, the overall financial resources of any parent corporation or entity; the overall size of the parent corporation or entity with respect to the number of its employees; the number, type, and location of its facilities; and (5) If applicable, the type of operation or operations of any parent corporation or entity, including the composition, structure, and functions of the workforce of the parent corporation or entity. (2010 ADA Definition)

Prioritization of Barrier Removal

- Section 36.304(c) from the Title III Regulations addresses prioritization for planning barrier removal projects
 - Priority 1: Accessible **approach and entrance** from parking, public transportation, sidewalks
 - Priority 2: Access to **goods and services**
 - Priority 3: Access to **rest rooms**
 - Priority 4: Any **other measures** necessary



Readily Achievable Barrier Removal



- Barrier removal is a continuing obligation
- Continues as the entity has the financial resources
- Entities that have more resources are expected to remove more barriers than those with fewer resources

Prioritization of Barrier Removal

- Setting priorities for barrier removal
 - Why are they there?
 - High use by visitors and patients, unsupervised
 - Public and patient use where supervision is provided
 - Patient areas where movement is controlled/patients are escorted, where they've been checked in for treatment or examination
 - Is it a room frequently used or one occasionally used?

Prioritization of Barrier Removal

- How far out of compliance/severe is the barrier?
 - Very subjective
 - Many different factors to consider
- Is it a safety issue?
- Is it a Safe Harbored element that is compliant with 1991 Standards?
- How does the barrier impact access?

Prioritization of Barrier Removal

- Some issues may be addressed by policies and procedures (for example, training of housekeeping staff to not place trash cans in door maneuvering clearance or next to the toilet)
- Maintenance-type items that could be addressed by facilities personnel

POLICIES AND PROCEDURES IN A HEALTHCARE SETTING

Policies



- Ensure that all services, procedures, examinations, treatment, and education are accessible to and usable by people with disabilities
- Implementation annually and as issues come up
- Method for receiving, responding to, and monitoring complaints
- Designated staff to respond to complaints

Policies

- Exceptions to policies:
- If you are able to demonstrate that making reasonable modifications would fundamentally alter the nature of the care you provide, you may use alternative methods
- If modification would result in a direct threat to the health or safety of others that cannot be eliminated or reduced to an acceptable level by reasonable modifications

Policies

- General Nondiscrimination Provisions and Notices
- Complaint/Grievance Process
- Accessible Equipment
 - Weight Measurement
 - Imaging
 - Exam Tables and Chairs
 - Patient Beds
 - Adaptations and Accommodations
- Accessible Facilities
 - Room and furniture layouts
 - Movable barriers

Policies

- Accommodation needs (accessible equipment such as patient beds, lifts, exam tables, etc.)
 - Document in patient medical record
- Lifting and Transferring
- Effective Communication
- Service Animals
- Maintenance of Accessible Features
- Websites and Mobile Applications
- Real Estate Transactions

Training

- General ADA principles
- Current policies and procedures
- New and revised policies and procedures
- Complaint process
- Contact person for ADA policy-related questions and complaints
- How to determine accessibility-related needs for patients, guests, and visitors
- Patient-care related skills (transfers, positioning, lifting, equipment, safety)

MAINTENANCE OF ACCESSIBLE FEATURES IN A HEALTHCARE SETTING

Maintenance of Accessible Features

§ 35.133 Maintenance of accessible features.

§ 36.211 Maintenance of accessible features.

(a) A public entity shall maintain in operable working condition those features of facilities and equipment that are required to be readily accessible to and usable by persons with disabilities by the Act or this part.

(b) This section does not prohibit isolated or temporary interruptions in service or access due to maintenance or repairs.

(c) If the 2010 Standards reduce the technical requirements or the number of required accessible elements below the number required by the 1991 Standards, the technical requirements or the number of accessible elements in a facility subject to this part may be reduced in accordance with the requirements of the 2010 Standards.

Maintenance of Accessible Features



- Facilities
- Equipment
- Routine and timely maintenance

ACCESSIBLE DIAGNOSTIC MEDICAL EQUIPMENT

Diagnostic Medical Equipment

- The ADA and Section 504 of the Rehabilitation Act require health care practitioners and delivery systems to provide full and equal access to health care services and facilities to people with disabilities, but neither of these laws address specific requirements for diagnostic medical equipment
- Section 4203 of the Patient Protection and Affordable Care Act (ACA) requires the U.S. Access Board, along with the FDA (Food and Drug Administration), to issue standards for accessible medical diagnostic equipment

Diagnostic Medical Equipment

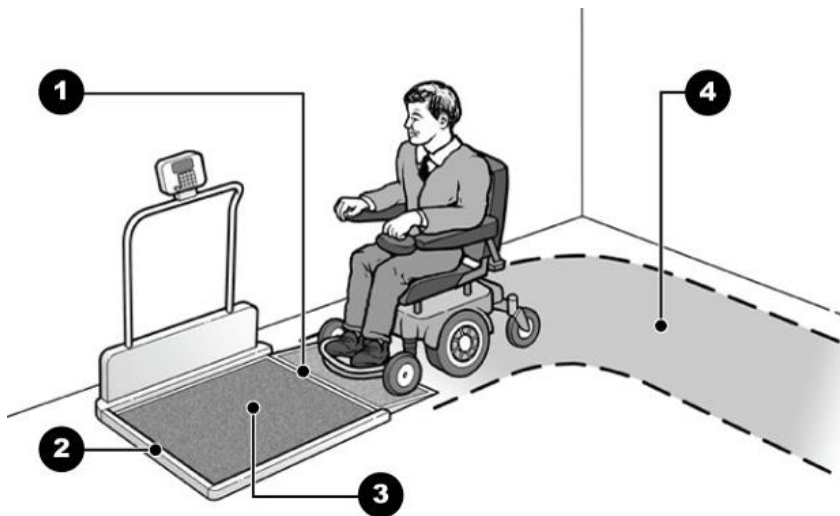
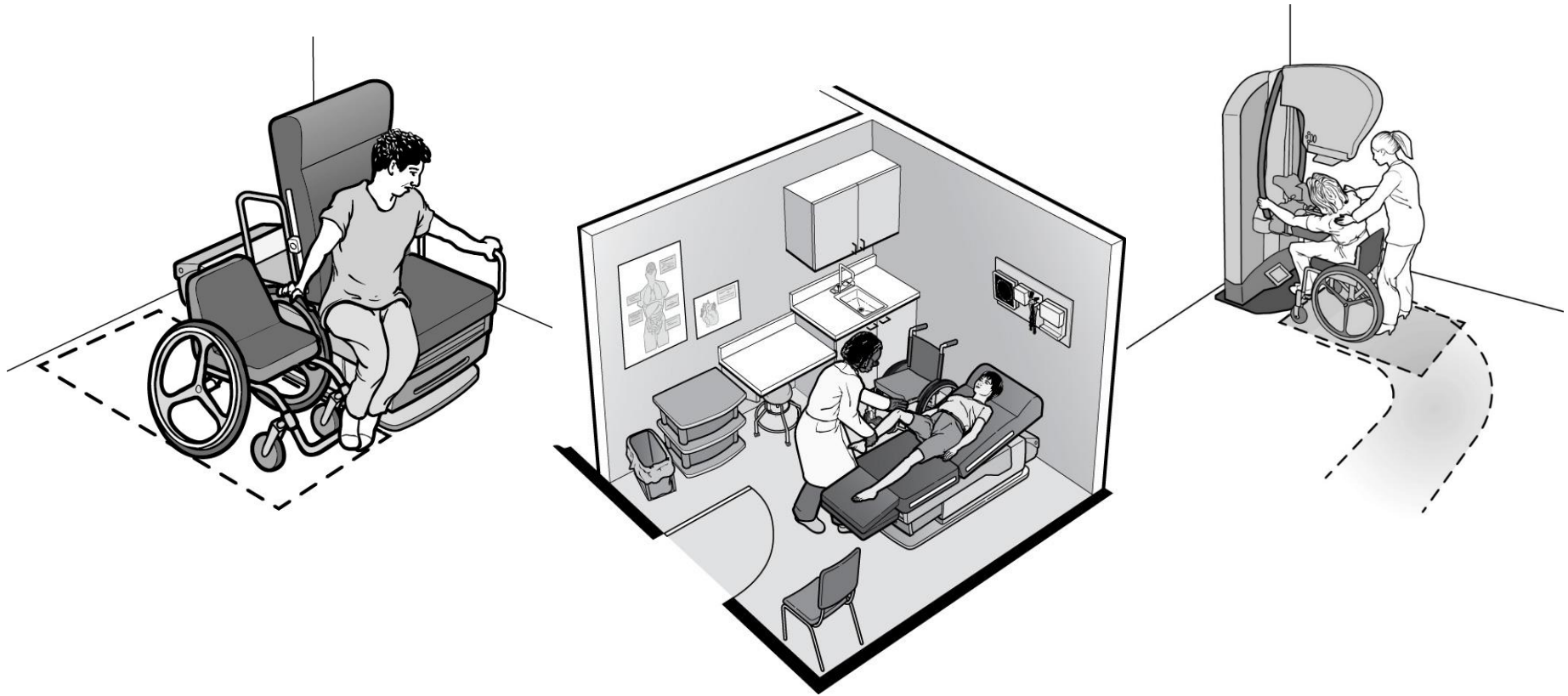

Image from "Access To Medical Care For Individuals With Mobility Disabilities"

- Technical criteria only
- Scoping to be applied by adopting agencies
- Voluntary standards until adopted

DOJ Guidance Document



Images from “Access To Medical Care For Individuals With Mobility Disabilities”

Diagnostic Medical Equipment

- Technical criteria is based on the position of the patient
 - Supine, prone, or side-lying position
 - Exam tables
 - Gurneys and stretchers
 - Seated position
 - Exam chairs (dental chairs, podiatry chairs, optometry chairs)
 - Mammography
 - Weight scales
 - Standing position
 - Mammography
 - Weight scales
 - Communication and operable parts

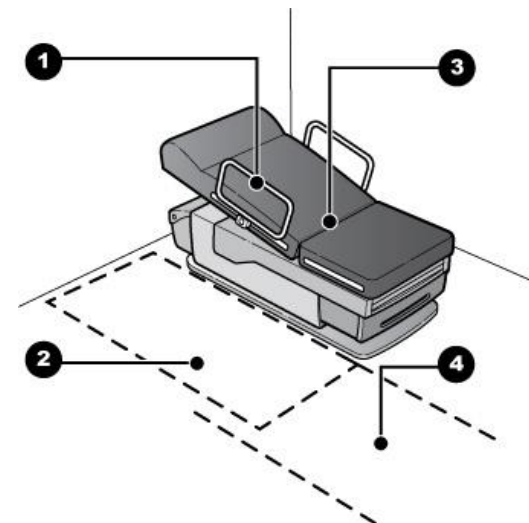

Image from "Access To Medical Care For Individuals With Mobility Disabilities"

Supine, Prone, or Side-Lying Position

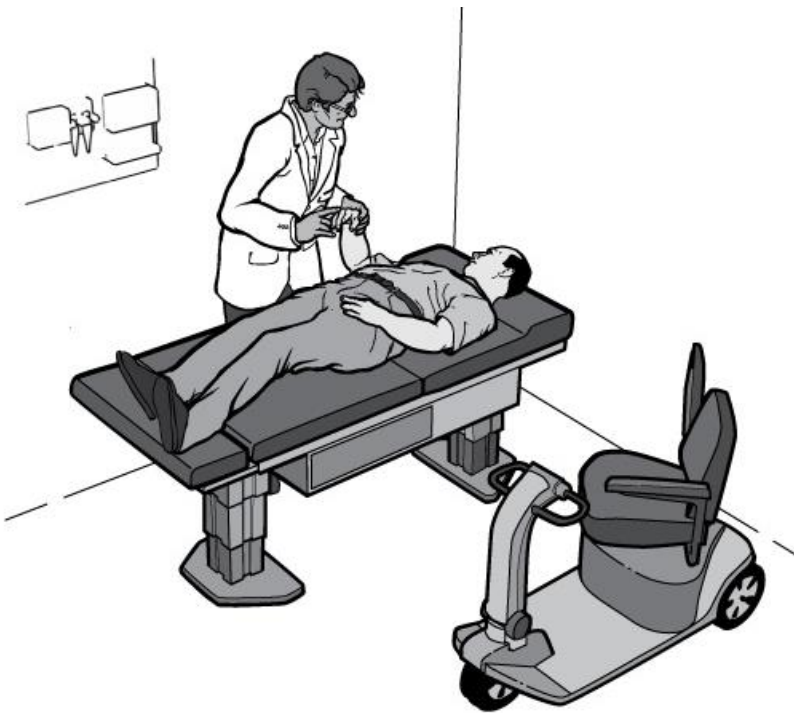

Image from "Access To Medical Care For Individuals With Mobility Disabilities"

- Supine, prone, or side-lying position
 - Transfer surface
 - Height, including height adjustability
 - Size of transfer surface
 - Transfer sides
 - Supports (transfer supports, stirrups/leg supports, head and back supports)
 - Lift compatibility

Seated Position

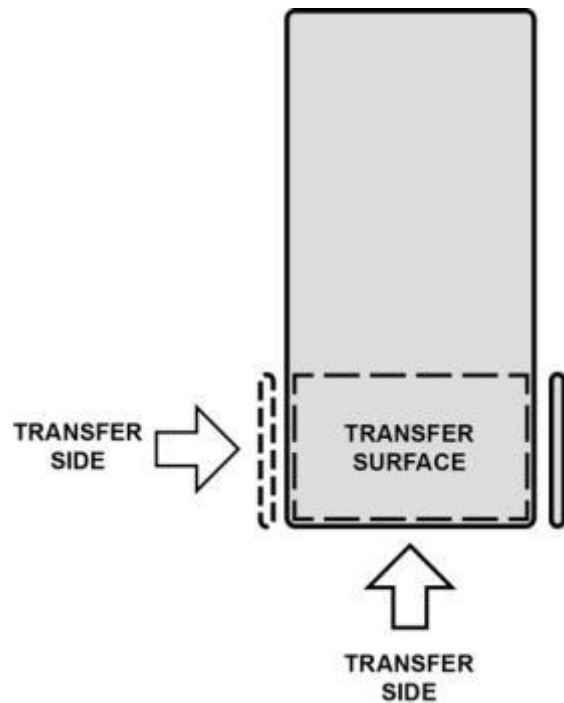

Image from US Access Board

- Seated position (where a transfer is made onto the equipment)
 - Transfer surface
 - Supports (transfer supports, armrests, head and back support)
 - Lift compatibility

Supine, Prone, Side-Lying, and Seated Position – Transfer Surface

- End Transfer Surface



- Side Transfer Surface

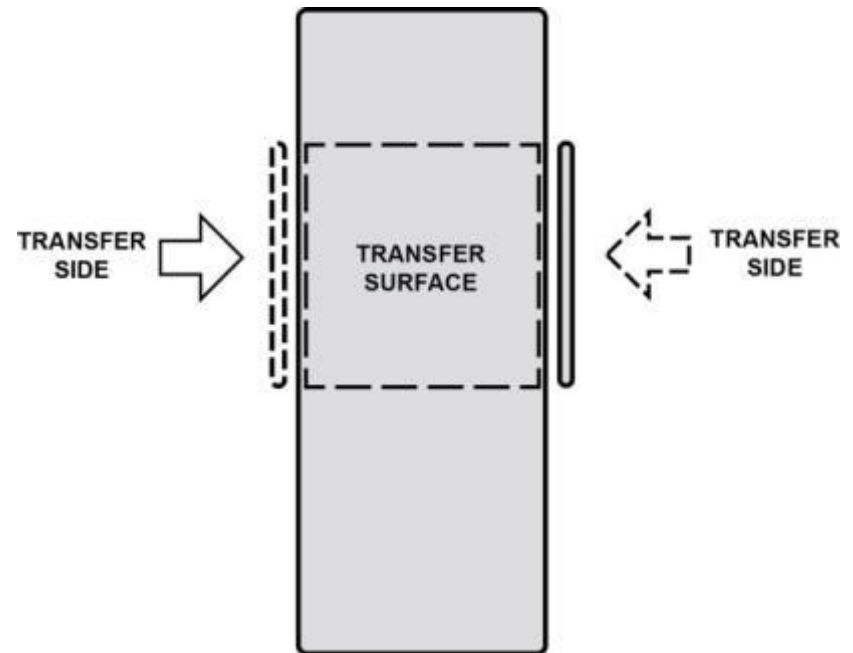

Images from US Access Board

Supine, Prone, Side-Lying, and Seated Position – Transfer Surface

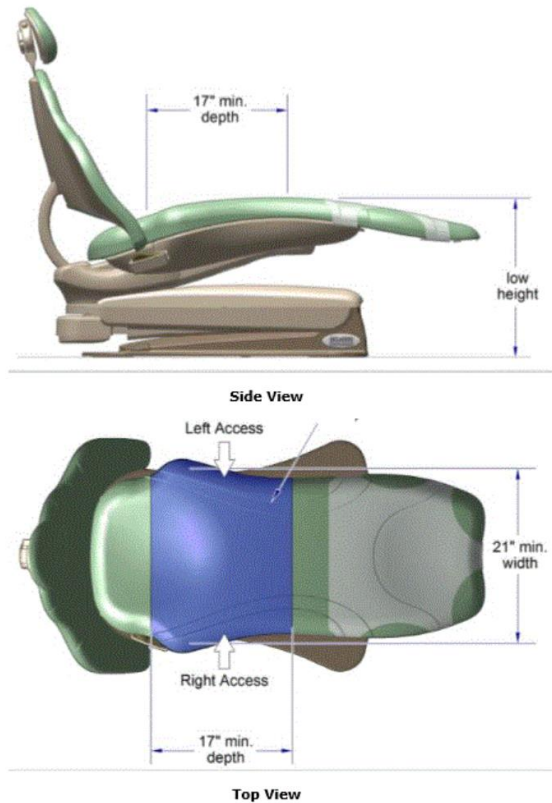

- Exam Chairs
 - Exception for chairs with fixed footrests

Image from US Access Board

Supine, Prone, Side-Lying, and Seated Position – Transfer Surface

- Advisory committee recommended:
 - Height adjustability for transfers
 - 25” high height of
 - 17”, 18”, 19” low height (no consensus)



Images from US Access Board

Supine, Prone, Side-Lying, and Seated Position – Transfer Surface

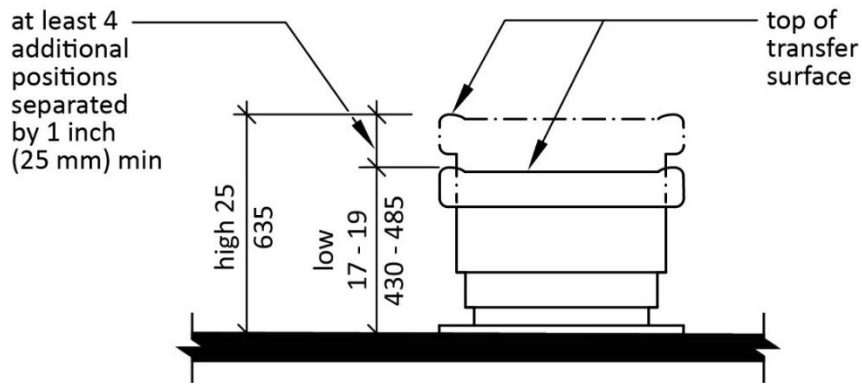

Image from US Access Board

- Sunset rule for Transfer Surface Height
- M301.2.2 Sunset
 - Low transfer position height ceases to have effect on January 22, 2022

Supine, Prone, Side-Lying, and Seated Position – Transfer Surface

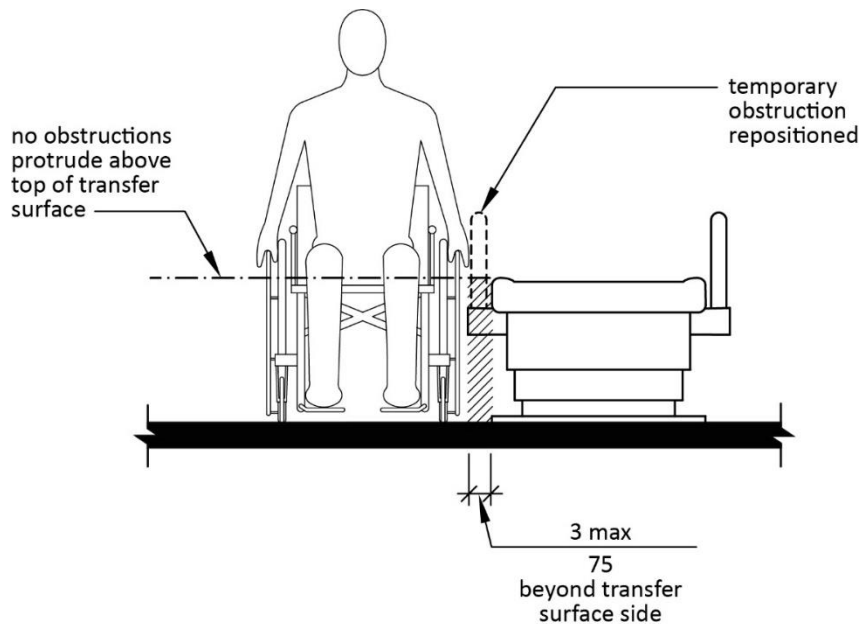

Image from US Access Board

- Permitted obstructions to transfer surface
- 3” maximum gap permitted at or below the transfer surface

Supports



Image from US Access Board

- Transfer supports
- Standing supports
- Leg supports
- Head and back supports

Lift Compatibility

- Compatibility in the base

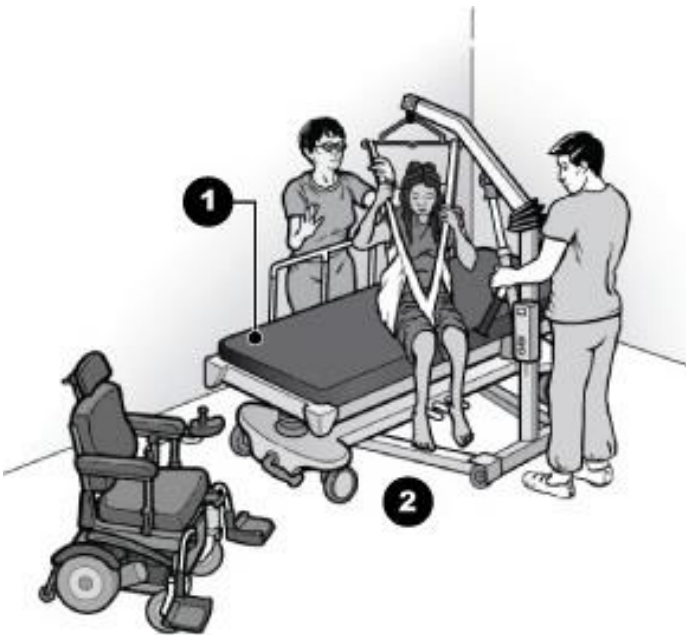

Image from "Access To Medical Care For Individuals With Mobility Disabilities"

- Compatibility around the base

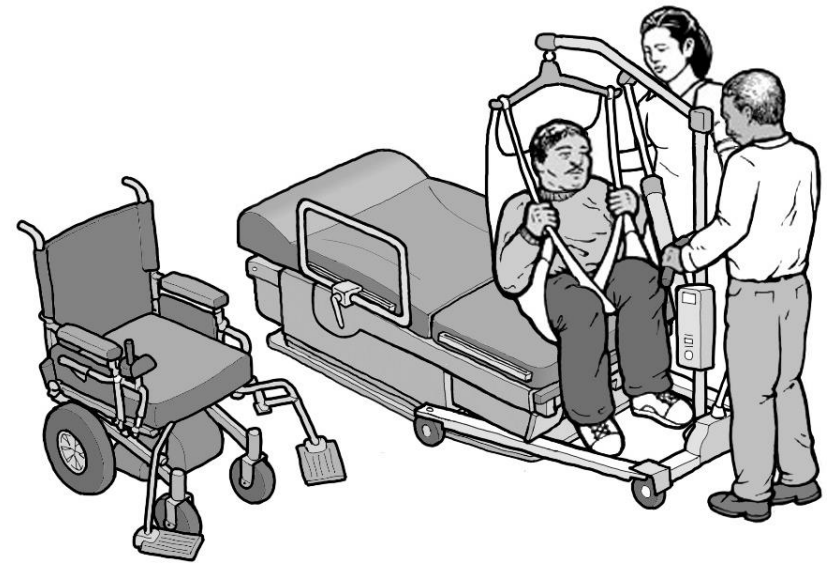
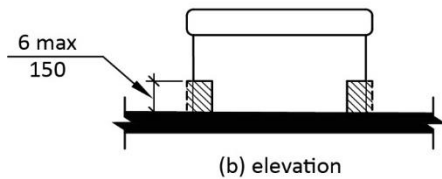
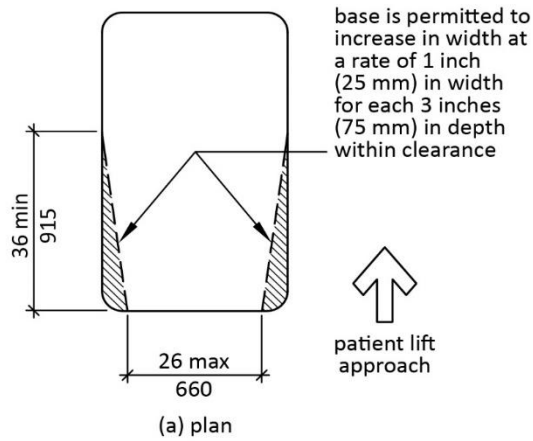

Image from US Access Board

Portable Patient Lifts

- Compatibility in the base



- Compatibility around the base

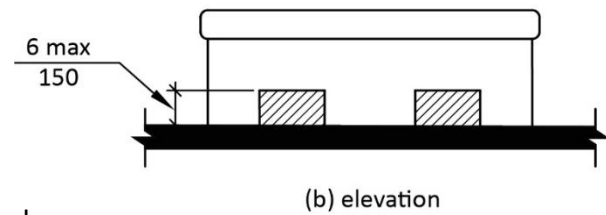
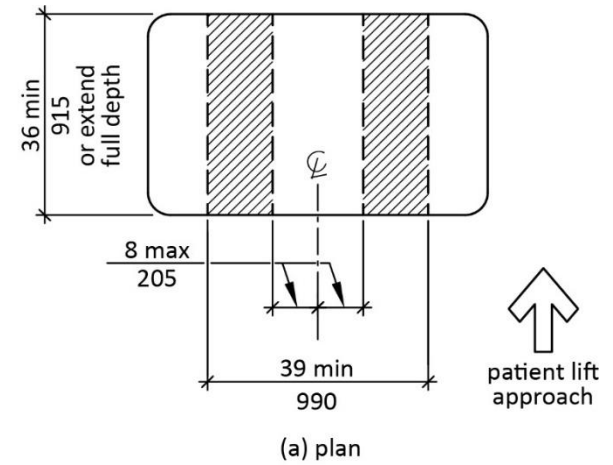

Images from US Access Board

Seated Position

- Seated position (patients seated in a mobility device)

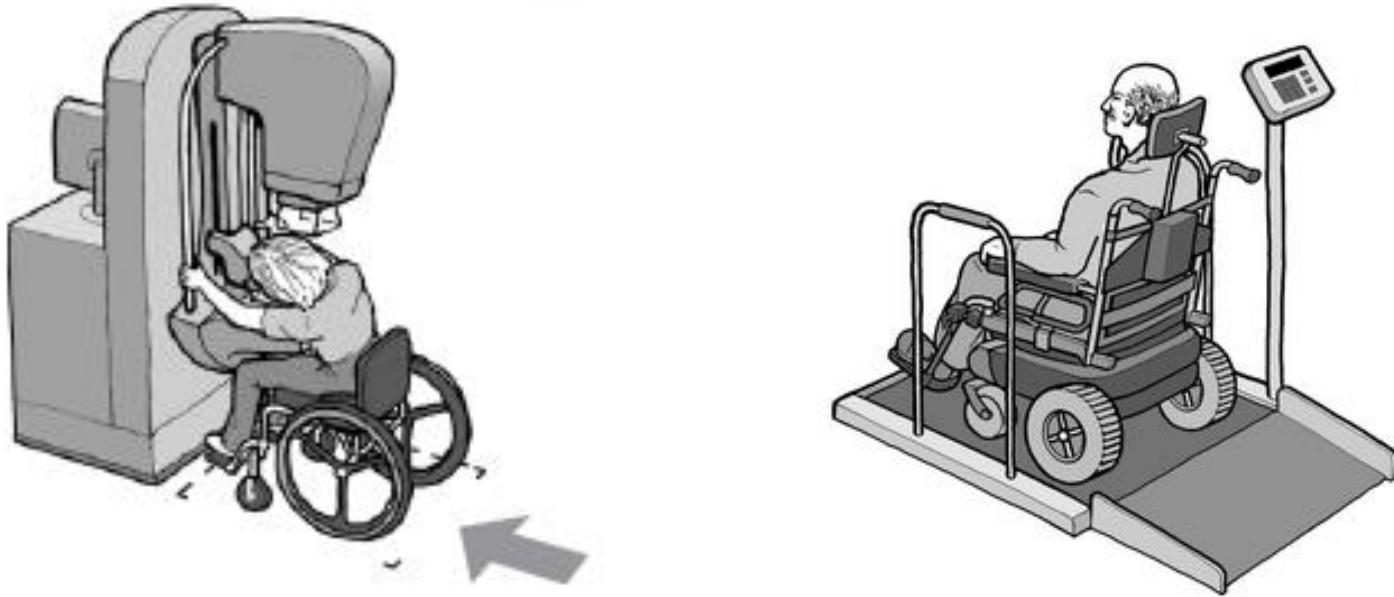

Images from US Access Board

Seated Position

- Wheelchair space (orientation, width, depth, knee/toe clearance)

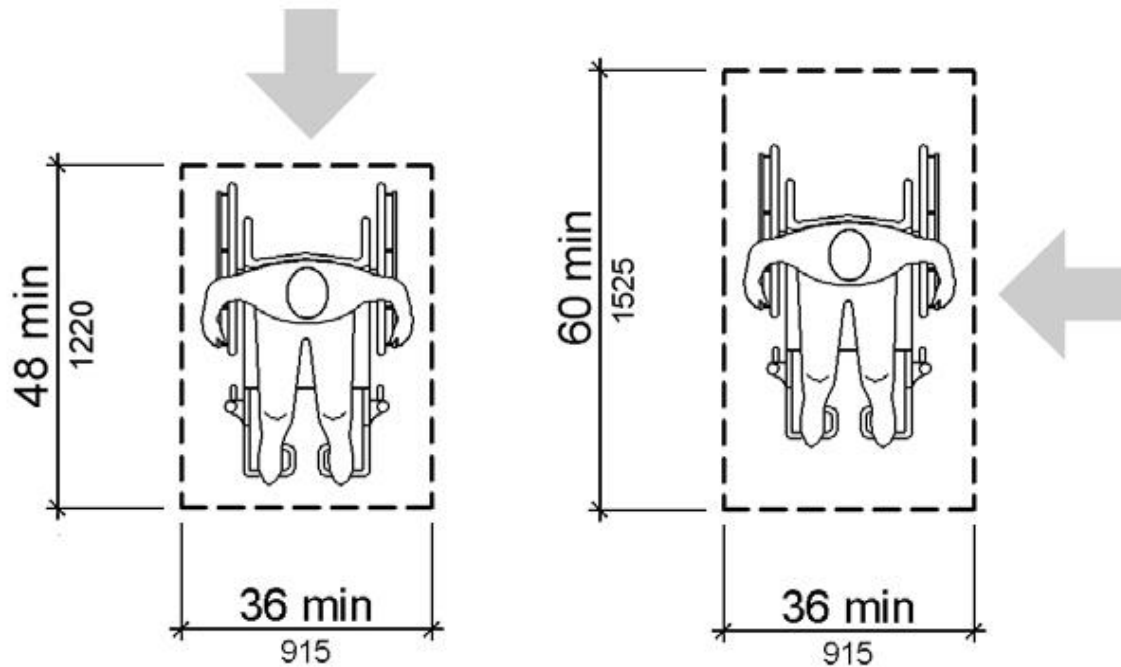

Image from US Access Board

Seated Position



Images from US Access Board

- Entry, including ramped surfaces
- Specific requirements for mammography
 - Breast platform height
 - Knee/toe clearance

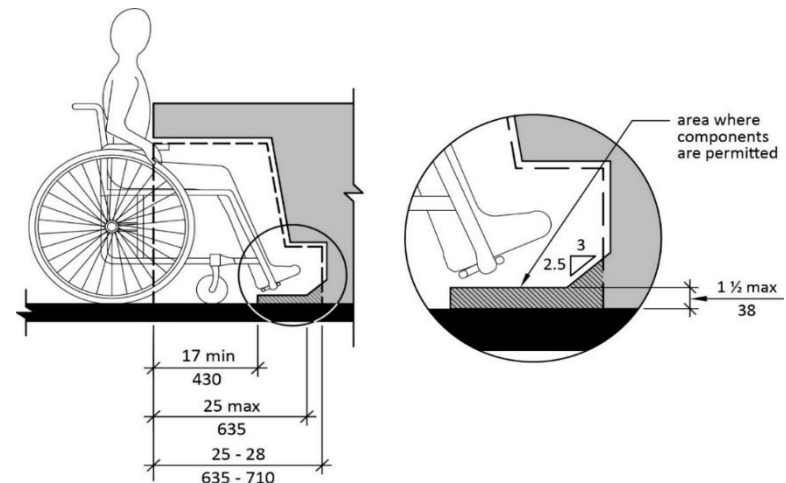

Standing Position

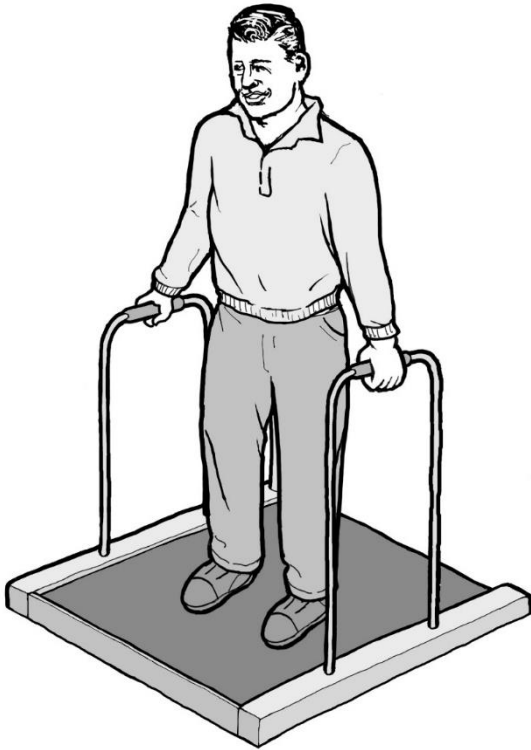

Image from US Access Board

- Standing surface
 - Slip resistant
- Standing supports
 - Horizontal
 - Vertical

Communication

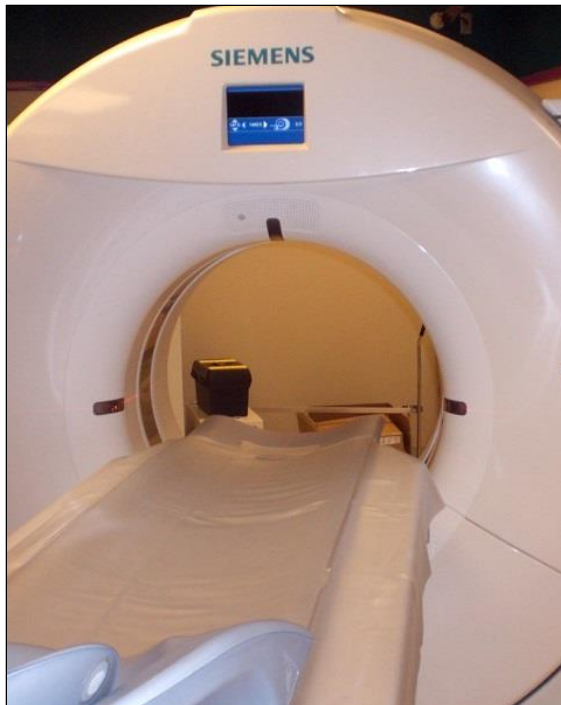

Image from US Access Board

- Information communicated through the equipment
- At least two modes of communication
 - Audible
 - Visible
 - Tactile

Operable Parts



Image from US Access Board

- Controls operated by the patient
 - Tactile discernibility
 - Operation
 - Operating force

The Big Picture

- Staff training
 - Operation, availability, and location of accessible medical equipment and related accessories
 - Transfers, positioning
 - Working with, communicating with, and assisting patients with disabilities
- Scheduling
 - Longer appointment times
 - Scheduling patients for specific exam or procedure rooms that provide accessible equipment
- Coordination
 - Accessible equipment located in accessible rooms

The Big Picture

- Sign language interpreters
- Printed materials in accessible formats
 - Large print
 - Braille
- Websites
- Evacuation procedures
- Gift shops
- Cafeterias and refreshment stations
- Trip hazards

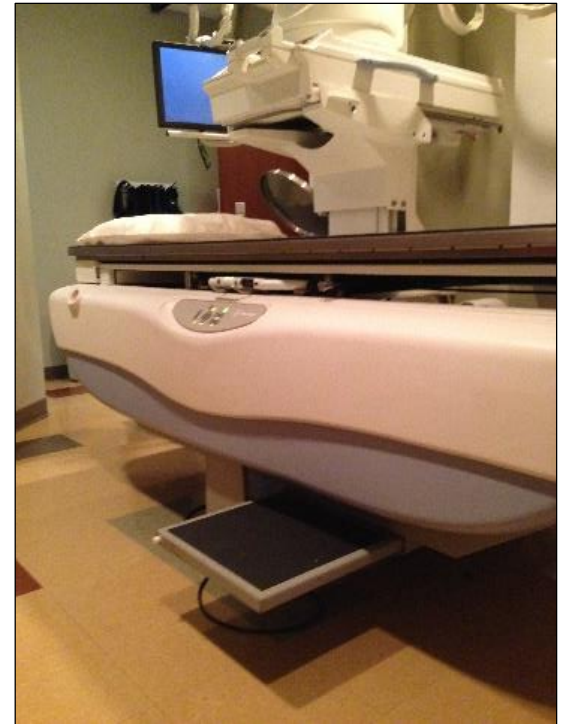

Additional Resources

- DOJ's "Access to Medical Care For Individuals with Disabilities"
https://www.ada.gov/medcare_mobility_ta/medcare_ta.htm
- DOJ's Standards for Accessible Design
https://www.ada.gov/2010ADAstandards_index.htm
- U.S. Access Board's Healthcare Page
<https://www.access-board.gov/guidelines-and-standards/health-care>

Contact Information

Kaylan M. Dunlap, CASp, ADAC, LPTA

Evan Terry Associates, LLC

One Perimeter Park South, Suite 200S

Birmingham, AL 35243

kdunlap@evanterry.com

205.972.9100 (Office)

256.506.7433 (Mobile)

www.Corada.com